

# EMERALD

The Education, Scholarships, Apprenticeships and Youth  
Entrepreneurship  
EUROPEAN NETWORK FOR 3D PRINTING OF BIOMIMETIC  
MECHATRONIC SYSTEMS

**IO4 - EMERALD e-case studies for project based  
learning method used in developing, testing and  
manufacturing of new biomimetic mechatronic systems  
by 3D printing technologies**

<b>Project Title</b>	European network for 3D printing of biomimetic mechatronic systems 21-COP-0019
<b>Output</b>	IO4 - EMERALD e-case studies for project based learning method used in developing, testing and manufacturing of new biomimetic mechatronic systems by 3D printing technologies
<b>Module</b>	IO4 – case studies - report
<b>Date of Delivery</b>	September 2023
<b>Authors</b>	Filip GÓRSKI, Razvan PACURAR, Filippo SANFILIPPO, Diana-Irinel BĂILĂ, Martin ZELENAY
<b>Version</b>	1.0, 30.09.2023

Disclaimer: This result was realized with the EEA Financial Mechanism 2014-2021 financial support. Its content (text, photos, videos) does not reflect the official opinion of the Programme Operator, the National Contact Point and the Financial Mechanism Office. Responsibility for the information and views expressed therein lies entirely with the author(s).

## Contents

1.	Introduction.....	3
2.	Case study proposal and initial concepts .....	4
3.	Case study brief descriptions.....	8
3.1.	Case study #1 – sensorized bicycle prosthesis .....	8
3.2.	Case study #2 – actuated mechatronic hand prosthesis.....	13
3.3.	Case study #3 – hand orthosis used as VR game controller.....	17
3.4.	Case study #4 – mechatronic sensorized leg orthosis.....	22
3.5.	Case study #5 – biomechatronic robotic arm .....	26
4.	Summary.....	28
	List of external results of case studies .....	29

Disclaimer: This result was realized with the EEA Financial Mechanism 2014-2021 financial support. Its content (text, photos, videos) does not reflect the official opinion of the Programme Operator, the National Contact Point and the Financial Mechanism Office. Responsibility for the information and views expressed therein lies entirely with the author(s).

## 1. Introduction

This document presents description of case studies realized in the EMERALD project, as of the IO4 work package. The cases were selected on the basis of experience, possibilities, available solutions by the combined teams of Poznan University of Technology (leading this work package), University of Agder, Technical University of Cluj-Napoca, National University of Bucharest and Bizzcom company.

The case studies were focused on five different examples of biomechatronic devices. Originally, four case studies (four different devices) were proposed. However, due to changes in project development, as well as advancements made by scientific teams, it was decided to include an additional, fifth case study of a robotic gripper device as another example to this work package.

The case studies were described in scientific papers, submitted to journals and/or conferences at various stages of development of the EMERALD project. They were also pursued by the students, realizing their Master's theses or doctoral experiments on their ideas. All these endeavors were presented in greater detail in separate documents – each case study is described in its appropriate report, available through website of EMERALD project (<https://project-emerald.eu>). In this document, basic premises, assumptions and plans are presented, as well as brief summaries of results related to each of the five cases.

Disclaimer: This result was realized with the EEA Financial Mechanism 2014-2021 financial support. Its content (text, photos, videos) does not reflect the official opinion of the Programme Operator, the National Contact Point and the Financial Mechanism Office. Responsibility for the information and views expressed therein lies entirely with the author(s).

## 2. Case study proposal and initial concepts

In general, the proposed cases were based on readily available solutions of prostheses and orthoses, made in previous projects by team of Poznan University of Technology. Of 4 cases, 2 are upper limb prostheses, 1 is upper limb orthosis and 1 is lower limb orthosis. In the case of the prostheses, it was proposed to convert them to mechatronic devices by making them sensorized (adding sensors of position and force) or active (adding motors to allow force grip). In the case of orthoses, it is proposed to enhance them with sensors, for possible gathering of information on their therapeutic use and making the therapy more effective, by including technologies such as VR or AR.

More information about the AutoMedPrint project that is the base of the cases can be found on the website – [automedprint.put.poznan.pl](http://automedprint.put.poznan.pl) (Polish language only, automatic translation recommended). The basic products on which the case studies 1-4 are based are shown in Figure 2.1.

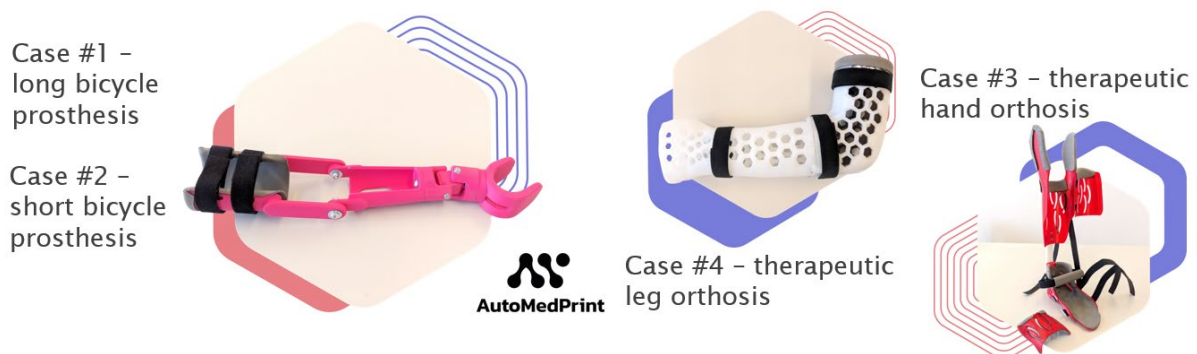

**Figure 2.1.** Basic case study products, based on AutoMedPrint project

In general, it was proposed that each case study involves conversion of a mechanical, 3D printed, anatomically customized device (prosthesis or orthosis) into a biomechatronic device, by adding sensors or actuators, to allow gathering data or force output. The whole development process was divided into six main stages. These stages are presented in Figure 2.2.

Disclaimer: This result was realized with the EEA Financial Mechanism 2014-2021 financial support. Its content (text, photos, videos) does not reflect the official opinion of the Programme Operator, the National Contact Point and the Financial Mechanism Office. Responsibility for the information and views expressed therein lies entirely with the author(s).

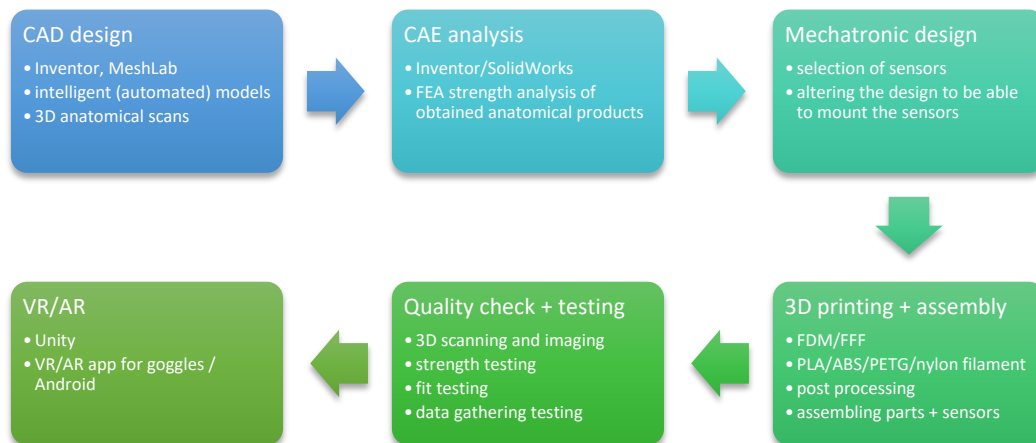

**Figure 2.2.** General workflow of development of case studies

The main assumptions of the first case study were as following:

- use of modular, intelligent CAD model of a prosthesis as a basis, with assumed transhumeral amputation/defect
- prosthesis designed for bicycle riding,
- biomimetics/mechatronics: sensorization of prosthesis (loading force + IMU),
- adult test patient (Figure 2.3),
- extensive use of VR/AR in prosthesis development.



**Figure 2.3.** Test patient – case study #1 [PUT materials]

For the second case study, the following assumptions were formulated:

Disclaimer: This result was realized with the EEA Financial Mechanism 2014-2021 financial support. Its content (text, photos, videos) does not reflect the official opinion of the Programme Operator, the National Contact Point and the Financial Mechanism Office. Responsibility for the information and views expressed therein lies entirely with the author(s).

- use of modular, intelligent CAD model as a basis – the same as in case #1, but with another type of amputation (transradial)
- prosthesis designed for general activities – grasping objects,
- biomimetics/mechatronics: powerization of end effector (basic gripping functionality),
- adult test patient (Figure 2.4),
- two construction versions for evaluation.



Figure 2.4. Test patient – case study #2 [PUT materials]

The third case study assumes the following:

- use of intelligent CAD model of hand orthosis, driven by 3D scanning data,
- rigid orthosis with openwork shape with cutouts for therapeutic exercises,
- sensorization of orthosis for therapeutic purposes, use in VR game therapy,
- juvenile test patient (Figure 2.5).

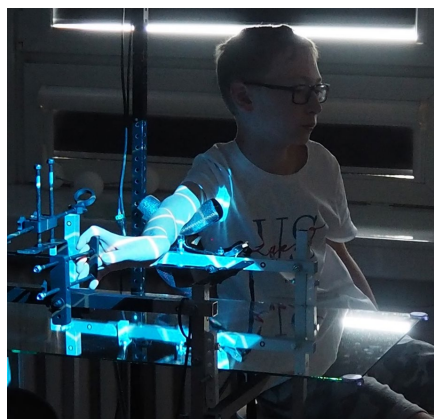

Disclaimer: This result was realized with the EEA Financial Mechanism 2014-2021 financial support. Its content (text, photos, videos) does not reflect the official opinion of the Programme Operator, the National Contact Point and the Financial Mechanism Office. Responsibility for the information and views expressed therein lies entirely with the author(s).

**Figure 2.5.** Test patient – case study #3 [PUT materials]

The assumptions for the fourth case study were the following:

- mesh-based design of lower leg (AFO) orthosis, with use of 3D scanning data,
- rigid orthosis for therapeutic exercises, for both legs,
- sensorization of orthosis for therapeutic purposes, use in VR/AR game therapy,
- juvenile or adult test patients (Figure 2.6).



**Figure 2.5.** Test patient – case study #4 [PUT materials]

The fifth case study was conceived right at the beginning of the project, but was initially thought to be used only for the toolkits and summer school events. However, additional studies were realized in the scope of the project, so it can now be considered as a full case study. The following assumptions were made:

- design of a 3D printable, easily programmable biomechatronic robotic gripper,
- analyzing possibilities of using various advanced materials (PEKK) and processes (PolyJet) in production of the gripper elements,
- material studies (FTIR, EDS and others), CAE strength calculations,
- 3D printing of various materials and experimental testing.

Disclaimer: This result was realized with the EEA Financial Mechanism 2014-2021 financial support. Its content (text, photos, videos) does not reflect the official opinion of the Programme Operator, the National Contact Point and the Financial Mechanism Office. Responsibility for the information and views expressed therein lies entirely with the author(s).

### 3. Case study brief descriptions

#### 3.1. Case study #1 – sensorized bicycle prosthesis

Case 1 is based on a mechanical 3D printed prosthesis made for one-handed cyclists (product codename: “Zosia”, construction under Polish patent application). The prosthesis is aimed at patients, who have no forearm and no elbow – with transhumeral amputation, or elbow disarticulation, or an inborn defect of the same effect.

Figure 3.1 presents various implementations of the prosthesis for patients.



**Figure 3.1.** Bicycle prosthesis used by various patients [PUT project report], test patient (40-year old male) to the right

The prosthesis itself is modular and is built of three main parts:

- 1) socket (stump/prosthesis interface) – 3 solutions are available (open, closed, compressive-release socket - CRS)
- 2) forearm (open/closed)
- 3) handle / end effector (open/closed/mechanical etc.)

Disclaimer: This result was realized with the EEA Financial Mechanism 2014-2021 financial support. Its content (text, photos, videos) does not reflect the official opinion of the Programme Operator, the National Contact Point and the Financial Mechanism Office. Responsibility for the information and views expressed therein lies entirely with the author(s).



Elements of the prosthesis are printed using regular FDM/FFF technology, of standard materials: PLA, PETG, PA12 (nylon), depending on requirements. Assembly requires use of standard components – rivets, nuts and bolts – as well as EVA foam for socket lining.

The prosthesis is designed on the basis of 3D scanning of a stump and a healthy limb and then measuring (semi-automated) on the processed scan. The measurements are entered into spreadsheet, which is fed to automated CAD model (made in Autodesk Inventor software). The model automatically adjusts its geometry to data of a given patient. It is also possible to perform manual measurements of patient limbs, if 3D scanner is not available – this is less precise and impossible to do in the case of CRS socket.

The test patient was a 40-year old male with a congenital defect – lack of forearm (equal to transhumeral amputation right above elbow – no elbow joint). The activities undertaken to realize the complete case study are listed below and described fully in a corresponding full case study report, as well as in some O2 EMERALD toolkits and scientific papers.

1. Design, production and improvement of mechanical prosthesis – 3D scanning of patient, design of initial version (as presented in Fig. 3.1) and later improvements – removing elbow coupling, simplifying wrist movement and improving of the gripper (Fig. 3.2).
2. Computer Aided Analysis – Finite Element Method calculations of the prosthesis mechanical part under load (Fig. 3.3).
3. Mechatronic design – conceiving, planning, adding and drawing scheme of electronic circuit (Fig. 3.4) and electronic components distribution in the orthosis.
4. Manufacturing and assembly of the mechatronic prosthesis (Fig. 3.5 and 3.6).
5. Tests with the patient (Fig. 3.7).
6. Preparation of XR applications (VR – 3.8, AR – 3.9, MR – 3.10) and testing of their usefulness in product development.

Disclaimer: This result was realized with the EEA Financial Mechanism 2014-2021 financial support. Its content (text, photos, videos) does not reflect the official opinion of the Programme Operator, the National Contact Point and the Financial Mechanism Office. Responsibility for the information and views expressed therein lies entirely with the author(s).

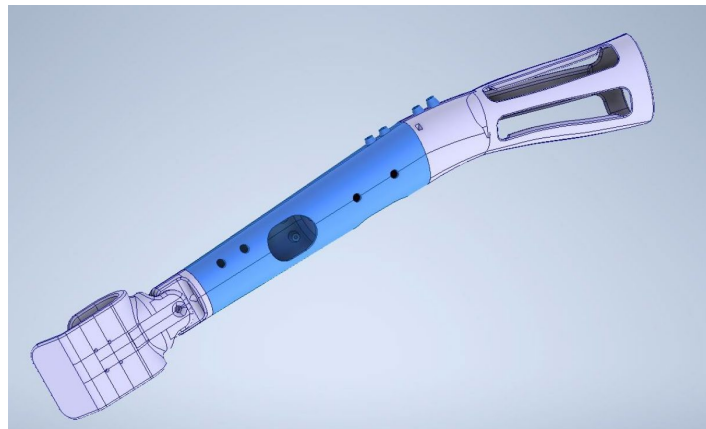

Figure 3.2. Construction improvements [2]

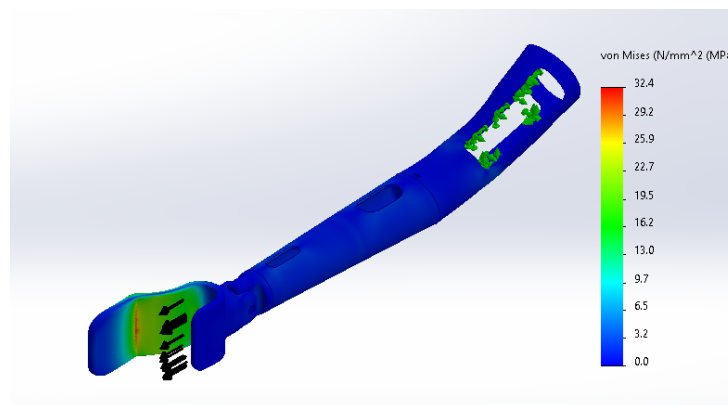

Figure 3.3. Finite Element Analysis [2]

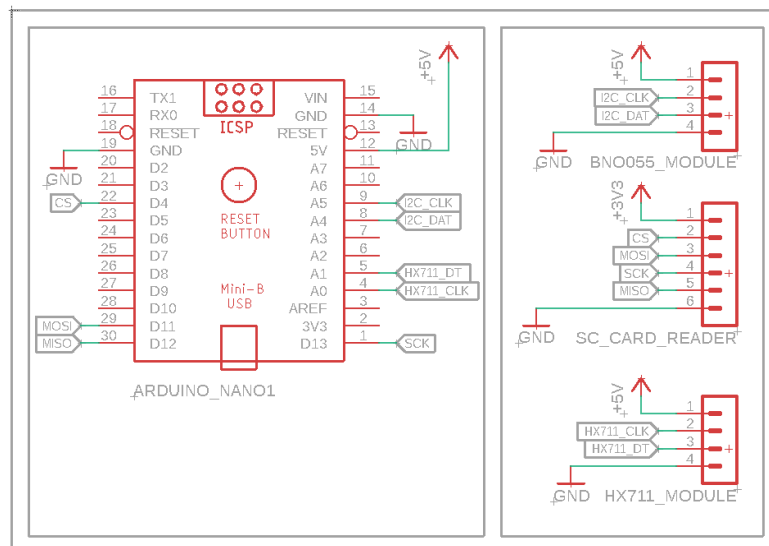

Figure 3.4. Electric scheme [2]

Disclaimer: This result was realized with the EEA Financial Mechanism 2014-2021 financial support. Its content (text, photos, videos) does not reflect the official opinion of the Programme Operator, the National Contact Point and the Financial Mechanism Office. Responsibility for the information and views expressed therein lies entirely with the author(s).

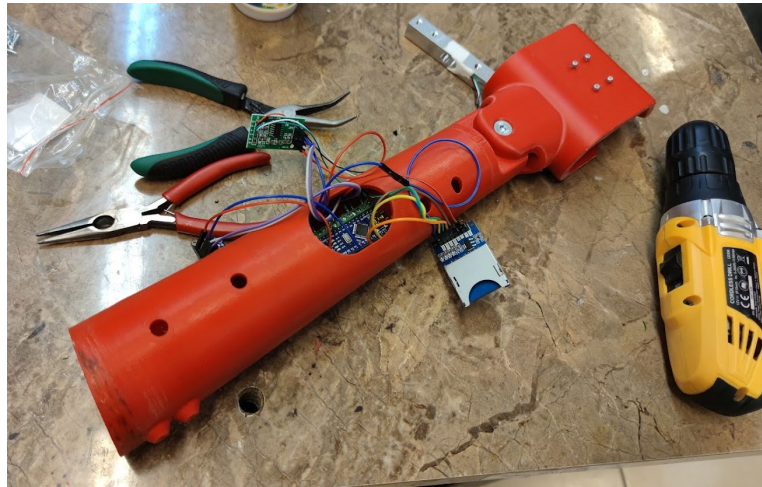

Figure 3.5. Mechatronic device assembly [2]



Figure 3.6. Full mechatronic prosthesis [2]

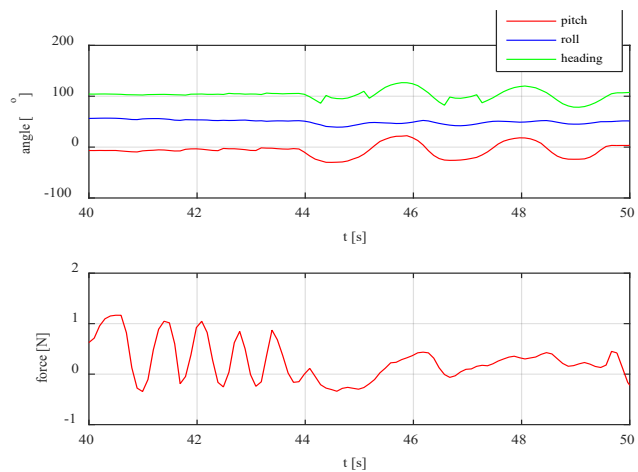

Figure 3.7. Test with patient with example of gathered data [2]

Disclaimer: This result was realized with the EEA Financial Mechanism 2014-2021 financial support. Its content (text, photos, videos) does not reflect the official opinion of the Programme Operator, the National Contact Point and the Financial Mechanism Office. Responsibility for the information and views expressed therein lies entirely with the author(s).

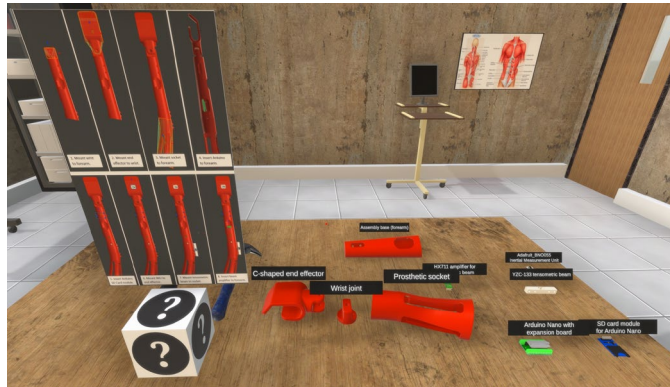

Figure 3.8. VR application [1]

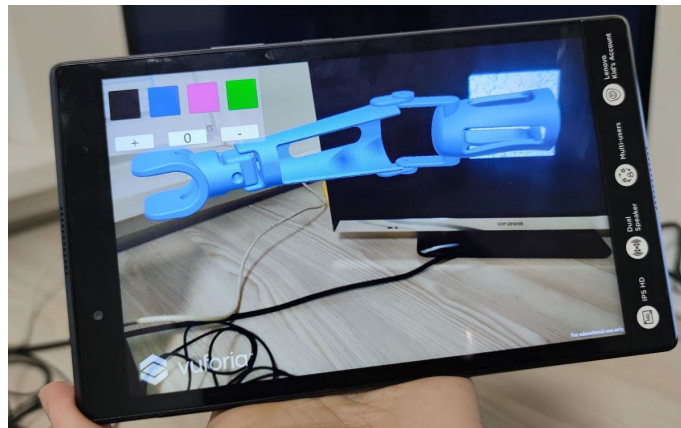

Figure 3.9. AR application [1]



Figure 3.10. MR application [1]

Disclaimer: This result was realized with the EEA Financial Mechanism 2014-2021 financial support. Its content (text, photos, videos) does not reflect the official opinion of the Programme Operator, the National Contact Point and the Financial Mechanism Office. Responsibility for the information and views expressed therein lies entirely with the author(s).

In conclusion, it was found that it is possible to build simple mechatronic sensorized prosthesis based on an individual 3D printed device and that data can be successfully gathered during the cycling. Further works are required on refining the concept.

The case study of the prosthesis was used in the following results of the EMERALD project (for more details, relate to dissemination report):

- 1) IO1 – CAD module
- 2) IO2 toolkits on CAD, CAE, VR/AR, assembly and testing
- 3) IO4 case study no. 1 report
- 4) Short Term Training Event (VR training)
- 5) Summer School in year 2023 (CAD, VR, MR exercise)
- 6) scientific paper (common) in Applied Sciences on effectiveness of XR in development of prosthetic devices [1] – published
- 7) scientific paper (common) in Applied Sciences, presenting the full case study [2] – accepted for publication
- 8) patent application for Polish Patent Office [3] – submitted

### *3.2. Case study #2 – actuated mechatronic hand prosthesis*

Case 2 is based on the same product – modular 3D printed hand prosthesis – as case 1. The general aim and design rules are different, as well as the patient case. The transradial amputation assumes there is a functioning elbow joint and a stump of a forearm. For such a case, it was assumed that a simple, low-cost 3D printed actuated prosthesis will be created, in two construction variants, to utilize either servomechanism or DC motor for the robotic gripper.

The test patient also was a 40-year old patient (refer to Fig. 2.4 and 3.11), with transradial amputation. The activities undertaken to realize the complete case study are listed below and described fully in a corresponding full case study report, as well as in EMERALD-related diploma thesis and scientific paper.

Disclaimer: This result was realized with the EEA Financial Mechanism 2014-2021 financial support. Its content (text, photos, videos) does not reflect the official opinion of the Programme Operator, the National Contact Point and the Financial Mechanism Office. Responsibility for the information and views expressed therein lies entirely with the author(s).

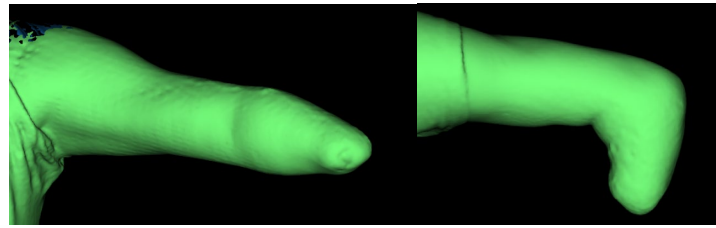

Figure 3.11. 3D scanned stump of the test patient

1. Design, production and improvement of mechanical prosthesis – 3D scanning of patient, design and testing (as presented in Fig. 2.4).
2. Mechatronic design – conceiving two variants of prosthesis, with different constructions, (Fig. 3.12 and 3.13).

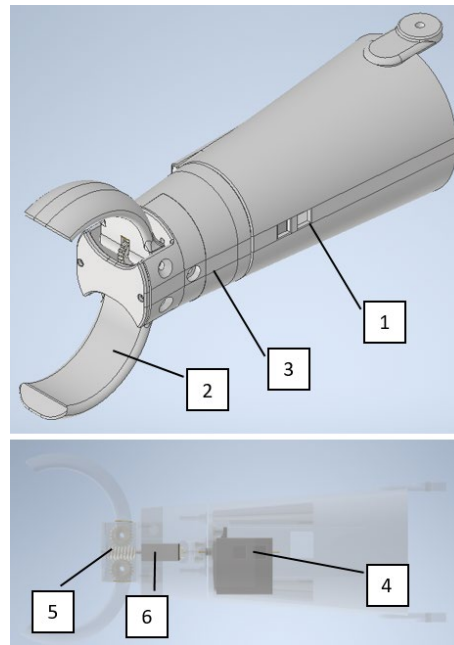
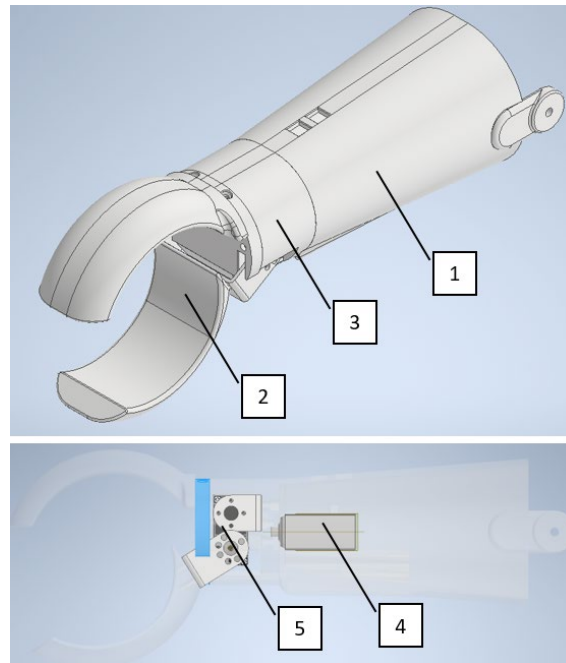

Figure 3.12 Prosthesis – variant 1 (1 – forearm, 2 – gripper, 3 – wrist, 4 – motor, 5 – wormgear, 6 – servo) [5]

Disclaimer: This result was realized with the EEA Financial Mechanism 2014-2021 financial support. Its content (text, photos, videos) does not reflect the official opinion of the Programme Operator, the National Contact Point and the Financial Mechanism Office. Responsibility for the information and views expressed therein lies entirely with the author(s).



**Figure 3.13** Prosthesis – variant 2 (1 – forearm, 2 – gripper, 3 – wrist, 4 – servo 1, 5 – servo 2) [5]

3. Manufacturing and assembly of two variants of the mechatronic prosthesis (Fig. 3.14).
4. Tests and evaluation with a group of experts (Fig. 3.15 and 3.16).



Disclaimer: This result was realized with the EEA Financial Mechanism 2014-2021 financial support. Its content (text, photos, videos) does not reflect the official opinion of the Programme Operator, the National Contact Point and the Financial Mechanism Office. Responsibility for the information and views expressed therein lies entirely with the author(s).

Figure 3.14 Prostheses – manufactured and assembled [4]



Figure 3.15 Functional tests, variant 1 (left) and 2 (right) [4]

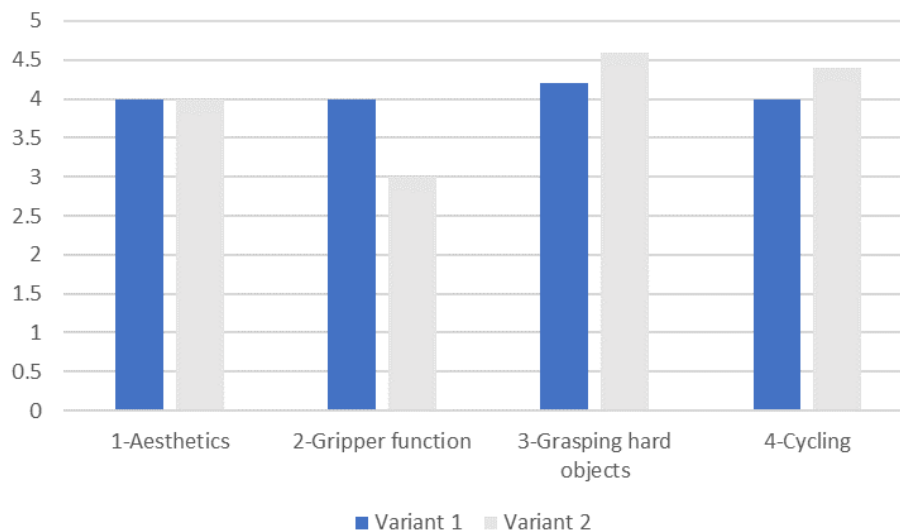

Figure 3.16. Prosthesis evaluation results in a group of experts – functions [5]

In conclusion, it was found that it is possible to easily prototype simple and low-cost mechatronic actuated prosthesis based on an individual 3D printed device and that it can be used functionally as a grasping device. Further works are required on refining the concept and evaluating it together with various patients.

The case study of the prosthesis was used in the following results of the EMERALD project (for more details, relate to dissemination report):

- 1) IO4 case study no. 2 report

Disclaimer: This result was realized with the EEA Financial Mechanism 2014-2021 financial support. Its content (text, photos, videos) does not reflect the official opinion of the Programme Operator, the National Contact Point and the Financial Mechanism Office. Responsibility for the information and views expressed therein lies entirely with the author(s).



- 2) diploma (Master's) thesis of a student of Mechatronics at Poznan University of Technology [4]
- 3) scientific paper in Springer, presenting the full case study [5] – submitted to Manufacturing 2024 conference

### 3.3. Case study #3 – hand orthosis used as VR game controller

Case 3 is based on a mechanical, rigid wrist hand orthosis, made as means of therapy for child patients with a condition known as Erb's palsy (shoulder dystocia), a birth defect resulting in lack of proper muscle development and tension in one arm, requiring therapy or surgery.

The solution for therapy of this condition in children is use of specialized orthosis, which mimics the shape of the healthy hand, to keep the affected hand in a correct position, gradually improving the hand shape. Also, such an orthosis allows easier grasping of various objects, as it shifts wrist to a position enabling such a grasp with an appropriate force. Examples of implementation are shown in Figure 3.17.



**Figure 3.17.** Corrective WHOs for patients with congenital paresis [PUT project report]

The orthosis contains of two parts (halves), joined together by snap-fit connection, as well as Velcro straps. The parts are 3D printed of PLA material (possibly also nylon, if needed due to higher operating temperature or waterproofness) and lined with EVA foam. Differing from typical WHOs, cutouts are made in one part, to allow finger bending for object grasping.

Disclaimer: This result was realized with the EEA Financial Mechanism 2014-2021 financial support. Its content (text, photos, videos) does not reflect the official opinion of the Programme Operator, the National Contact Point and the Financial Mechanism Office. Responsibility for the information and views expressed therein lies entirely with the author(s).

The orthosis is designed by 3D scanning (Fig. 2.5). Both upper limbs are scanned. The image of hand and wrist of healthy limb is mirrored and joined with image of forearm of the affected arm (verified by certified physiotherapist for anatomical correctness), thus obtaining an “ideal image” of the affected arm. On this basis, points are generated and fed to a CAD model (Inventor) by a spreadsheet. It is possible to quickly generate orthoses for various patients.

In order to make a case for the EMERALD project, it was proposed to enhance the orthosis with specialized sensors, allowing to both gather data about the therapeutic process and make the therapy more attractive, by using signal from the sensors to control a simple VR therapeutic game.

The test patient was a 15-year old patient (Fig. 2.5), with transradial amputation. The activities undertaken to realize the complete case study are listed below and described fully in a corresponding full case study report, as well as in EMERALD-related diploma thesis and scientific paper.

1. Design, production and improvement of mechanical orthosis – 3D scanning of patient (Fig. 2.5), design and testing (Fig. 3.18).
2. Mechatronic design – converting orthosis into VR game controller (Fig. 3.19 and 3.20).
3. Manufacturing and assembly of the orthosis (Fig. 3.21).
4. Creating VR game for therapy, with participation of a physiotherapist.
5. Tests and evaluation with a group of healthy subjects and the test patient (Fig. 3.22).

Disclaimer: This result was realized with the EEA Financial Mechanism 2014-2021 financial support. Its content (text, photos, videos) does not reflect the official opinion of the Programme Operator, the National Contact Point and the Financial Mechanism Office. Responsibility for the information and views expressed therein lies entirely with the author(s).



Figure 3.18. Corrective WHO for test patient – different versions [7]

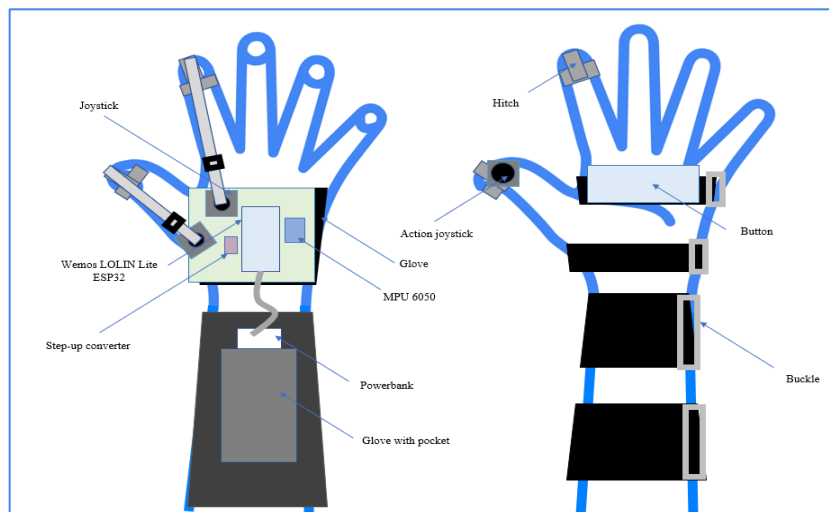

Figure 3.19. Concept of orthosis – VR game controller – electronic part [6,8]

Disclaimer: This result was realized with the EEA Financial Mechanism 2014-2021 financial support. Its content (text, photos, videos) does not reflect the official opinion of the Programme Operator, the National Contact Point and the Financial Mechanism Office. Responsibility for the information and views expressed therein lies entirely with the author(s).

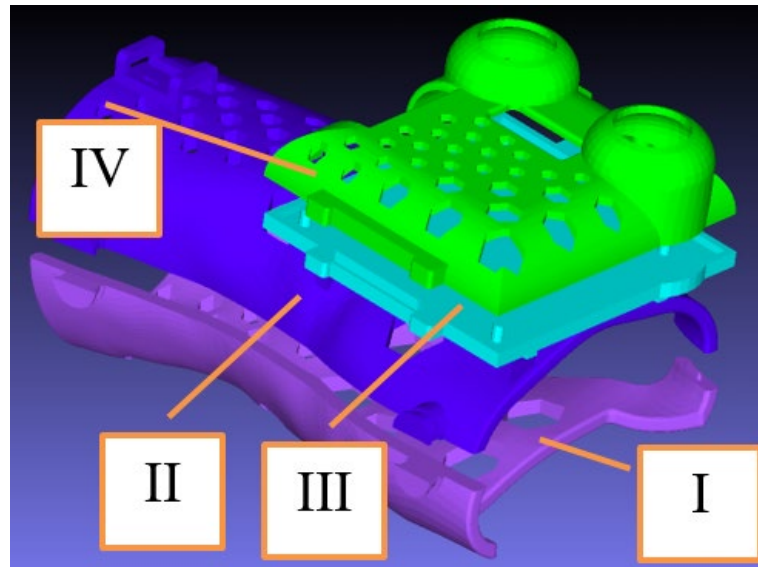

Figure 3.20. Mechatronic WHO – game controller [9] (I – customized orthosis lower part, II – orthosis upper part, III – VR controller shell – lower part, IV – VR controller shell – upper part)



Figure 3.21. Mechatronic orthosis – assembled [6,8]

Disclaimer: This result was realized with the EEA Financial Mechanism 2014-2021 financial support. Its content (text, photos, videos) does not reflect the official opinion of the Programme Operator, the National Contact Point and the Financial Mechanism Office. Responsibility for the information and views expressed therein lies entirely with the author(s).

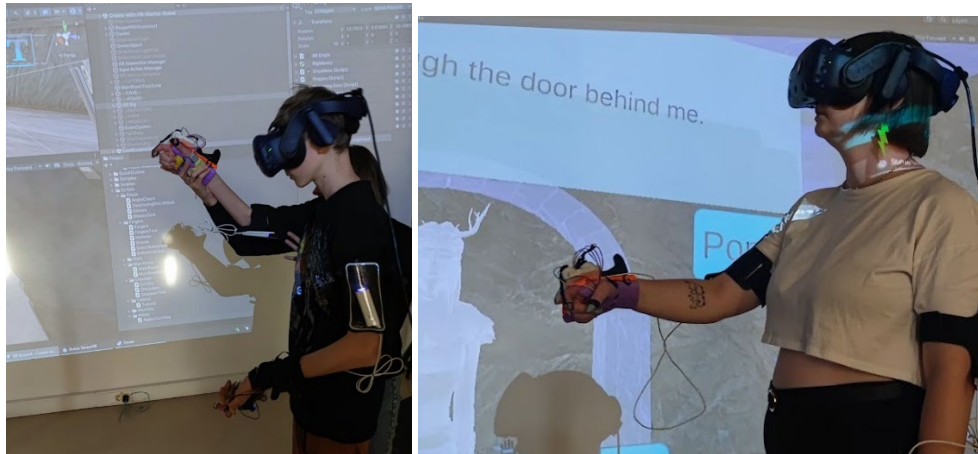

Figure 3.22. Testing of VR rehabilitation game [8]

In conclusion, it was found that it is possible to convert the standard, 3D printed customized orthosis into VR game controller, usable in rehabilitation of patients who cannot normally use typical VR controllers, due to deficits in hand motion. Further work is required on refining the concept and evaluating it together with various patients.

The case study of the orthosis was used in the following results of the EMERALD project (for more details, relate to dissemination report):

- 1) IO1 – CAD module
- 2) IO4 case study no. 3 report
- 3) Summer School in year 2022 and 2023 (CAD, VR, MR exercises)
- 4) diploma (Master's) thesis of a student of Mechatronics at Poznan University of Technology [6] presenting the main concept
- 5) scientific paper in Springer, presenting the development process of the mechanical orthosis – accepted for publication (full paper), abstract published [7]
- 6) scientific paper (common) in Electronics presenting the full case study [8] – accepted for publication
- 7) patent application for Polish Patent Office [9] – submitted
- 8) diploma (Master's) thesis of a student of Mechatronics at Poznan University of Technology [10] presenting an alternative concept

Disclaimer: This result was realized with the EEA Financial Mechanism 2014-2021 financial support. Its content (text, photos, videos) does not reflect the official opinion of the Programme Operator, the National Contact Point and the Financial Mechanism Office. Responsibility for the information and views expressed therein lies entirely with the author(s).

### 3.4. Case study #4 – mechatronic sensorized leg orthosis

Case 4 is based on a solution made for patients with severe mobility deficits, resulting of different conditions – spina bifida, cerebral palsy etc. The particular case concerns a 13-year old patient, who can walk on his own only when using specialized, expensive orthoses. Figure 3.23 shows the orthoses and their implementation in use.



**Figure 3.23.** 3D printed waterproof AFOs for patient with severe spina bifida [PUT materials]

The orthoses were designed on the basis of 3D scanning and 3D printed using nylon and PETG materials, on specialized 3D printers (delta kinematics, large working chamber). As opposed to the other cases, the CAD model is not yet automated, it was manually designed for the specific patient (automation is in progress).

In order to make a case for the EMERALD project, it was proposed to enhance the orthosis with specialized sensors, allowing to both gather data about the therapeutic process and make the therapy more attractive, by possibly using signal from the sensors to control a simple VR game.

It was decided to realize the case study on a case of adult patient with only minimal movement restrictions resulting of previous injuries. The activities undertaken to realize the complete case study are listed below and described fully in a corresponding full case study report, as well as in EMERALD-related diploma thesis and patent application.

1. Mesh-based design and additive production of mechanical orthosis – 3D scanning of patient (Fig. 3.24), design (Fig. 3.25), manufacturing.
2. Mechatronic design – converting orthosis into sensorized device (Fig. 3.26).

Disclaimer: This result was realized with the EEA Financial Mechanism 2014-2021 financial support. Its content (text, photos, videos) does not reflect the official opinion of the Programme Operator, the National Contact Point and the Financial Mechanism Office. Responsibility for the information and views expressed therein lies entirely with the author(s).

3. Manufacturing and assembly of the orthosis, electronic part (Fig. 3.27) and complete mechatronic orthosis.
4. Tests and evaluation with a healthy subject (Fig. 3.28).

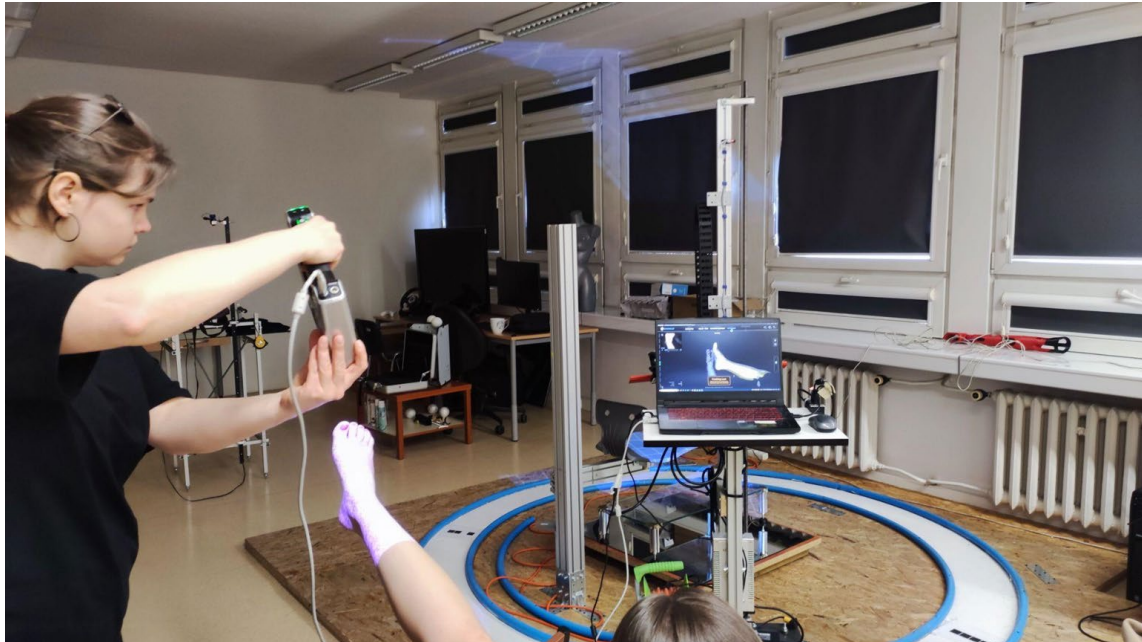

Figure 3.24. 3D scanning [11]

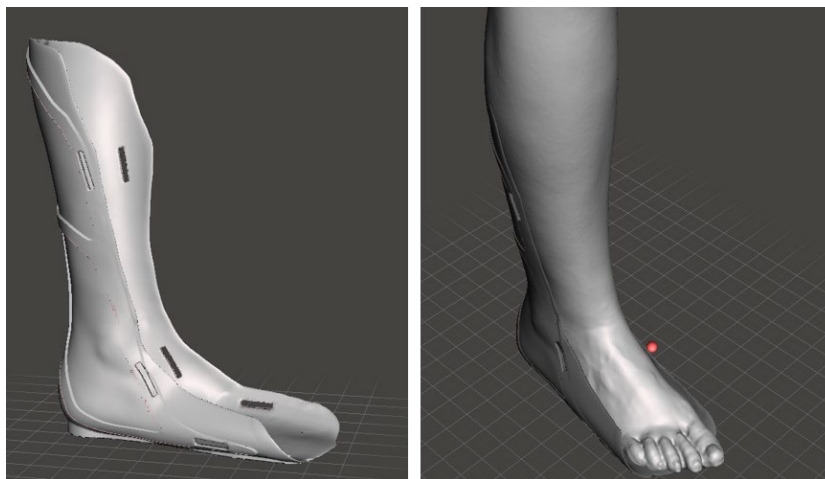
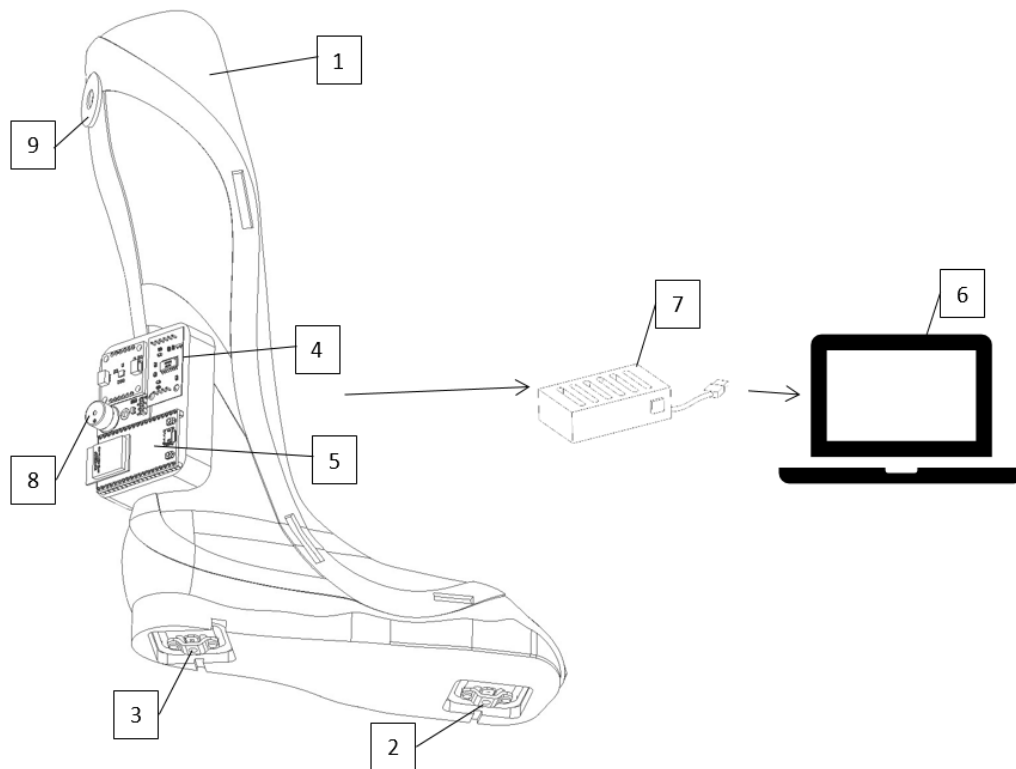
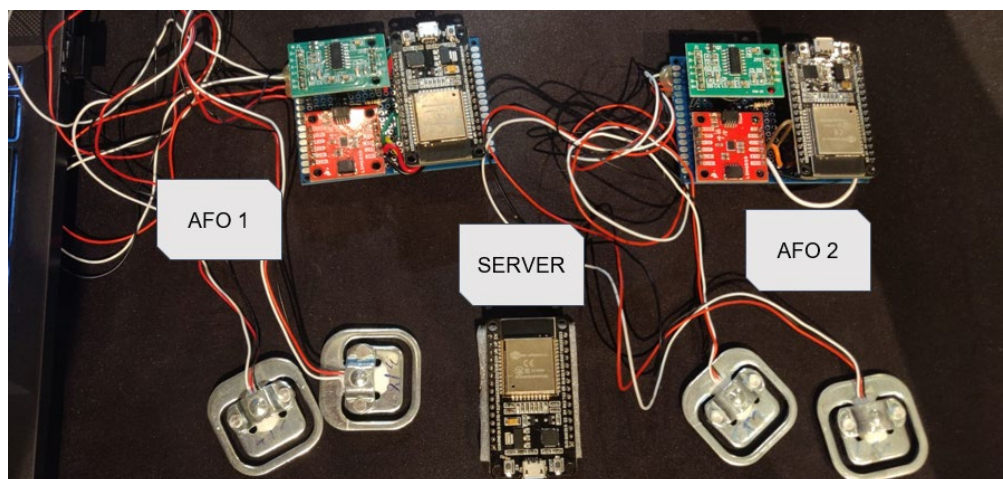

Figure 3.25. Design – mechanical part (mesh-based) [11]

Disclaimer: This result was realized with the EEA Financial Mechanism 2014-2021 financial support. Its content (text, photos, videos) does not reflect the official opinion of the Programme Operator, the National Contact Point and the Financial Mechanism Office. Responsibility for the information and views expressed therein lies entirely with the author(s).



**Figure 3.26.** Mechatronic orthosis design, 1-orthosis shell, 2,3 – force sensors, 4 – IMU, 5 – microcontroller, 6 – computer receiver, 7 – server, 8 – buzzer, 9 – mounting of positional tracker [13]



**Figure 3.27.** Assembly of electronic part [11]

Disclaimer: This result was realized with the EEA Financial Mechanism 2014-2021 financial support. Its content (text, photos, videos) does not reflect the official opinion of the Programme Operator, the National Contact Point and the Financial Mechanism Office. Responsibility for the information and views expressed therein lies entirely with the author(s).





**Figure 3.28.** Testing [11]

The case study of the orthosis was used in the following results of the EMERALD project (for more details, relate to dissemination report):

- 1) IO4 case study no. 4 report
- 2) Summer School in year 2023 (VR, MR exercises)
- 9) diploma (Master's) thesis of a student of Mechatronics at Poznan University of Technology [11]
- 3) scientific presentation held at Conference of Biomedical Engineering at Poznan University of Technology in 2023, abstract published [12]
- 4) patent application (common patent) for Polish Patent Office [13] – submitted

Disclaimer: This result was realized with the EEA Financial Mechanism 2014-2021 financial support. Its content (text, photos, videos) does not reflect the official opinion of the Programme Operator, the National Contact Point and the Financial Mechanism Office. Responsibility for the information and views expressed therein lies entirely with the author(s).

### 3.5. Case study #5 – biomechatronic robotic arm

The case study #5 focuses on a biomechatronic 3D printable robotic arm that can be used as a haptic device. The robotic arm was constructed as a project realized by University of Agder lecturers and students, as an educational example on how to construct and program simple robotic grippers. It has been used during the EMERALD project summer school in year 2022, in form of a toolkit available on GitHub platform [14], by students of all universities involved in the project consortium. Then, in the later phase of the project, the EMERALD consortium members realized material studies on the gripper, realizing 3D prints, tests and analyzes using various techniques and materials.

. The activities undertaken to realize the complete case study are listed below and described fully in a corresponding full case study report, as well as in EMERALD-related scientific paper.

1. Design, programming and testing of the robotic gripper (Fig. 3.29).
2. Selection of materials and material testing (FTIR, EDS and other methods).
3. CAE – FEM analysis of gripper made of different materials.
4. 3D printing of gripper parts with different technologies and materials.
5. Mechanical testing of 3D printed parts , economical evaluation.



Figure 3.29. The robotic gripper 3D design

Disclaimer: This result was realized with the EEA Financial Mechanism 2014-2021 financial support. Its content (text, photos, videos) does not reflect the official opinion of the Programme Operator, the National Contact Point and the Financial Mechanism Office. Responsibility for the information and views expressed therein lies entirely with the author(s).

The software was built to be as modular as possible, aiming to ensure the easy operation of the robotic arm for users with varying programming backgrounds. The course is designed to cater to students with minimal to no prior experience in programming and control theory while also providing the opportunity for experienced personnel to conduct advanced control theory testing. The parts of the robot arm were 3D printed using the Fused Filament Fabrication technology, of PLA material. Using standard nuts and bolts, springs and other elements, mechanical part and actuators were assembled. Using Arduino, sensors and other electronic components, the electronic part was assembled. The result is presented in Figure 3.30. Total of 4 arms were manufactured and successfully launched.

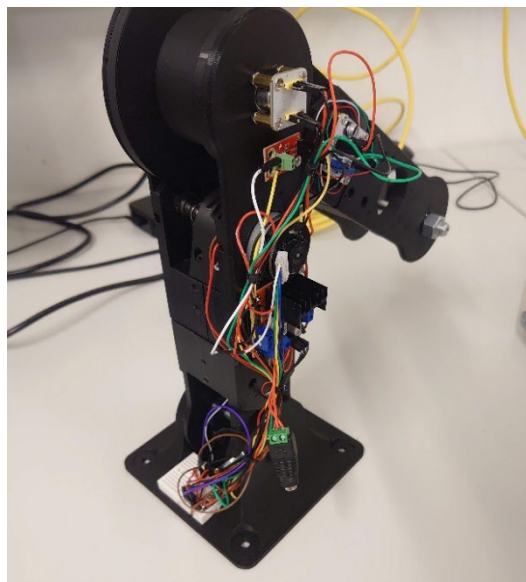

**Figure 3.30.** Assembled robotic arm made of 3D printed components [14]

The case study of the robotic gripper was used in the following results of the EMERALD project (for more details, relate to dissemination report):

- 1) IO2 toolkit on robotics, available also as GitHub solution [14]
- 2) IO4 case study no. 5 report
- 3) Summer School in year 2022 (assembly and programming exercises)
- 4) diploma (Master's) thesis of students at University of Agder
- 5) scientific paper prepared for journal Frontiers in Materials [15]

Disclaimer: This result was realized with the EEA Financial Mechanism 2014-2021 financial support. Its content (text, photos, videos) does not reflect the official opinion of the Programme Operator, the National Contact Point and the Financial Mechanism Office. Responsibility for the information and views expressed therein lies entirely with the author(s).

#### 4. Summary

In this document, brief presentation of all five case studies of EMERALD project are presented. A broad range of prosthetic, orthotic and robotic biomechatronic devices were created in this intellectual output, far exceeding the initial expectations, with a number of new promising study directions opened and possibly grant applications as well. The cases were shortly presented and described, along with list of external results they generated (theses, papers, patents etc.). Detailed descriptions of each case can be found in the mentioned papers or theses, as well as in separate case study reports prepared in the scope of the project.

Disclaimer: This result was realized with the EEA Financial Mechanism 2014-2021 financial support. Its content (text, photos, videos) does not reflect the official opinion of the Programme Operator, the National Contact Point and the Financial Mechanism Office. Responsibility for the information and views expressed therein lies entirely with the author(s).

## List of external results of case studies

1. Górski F, Łabudzki R, Żukowska M, Sanfilippo F, Ottestad M, Zelenay M, Băilă D-I, Pacurar R. Experimental Evaluation of Extended Reality Technologies in the Development of Individualized Three-Dimensionally Printed Upper Limb Prostheses. Applied Sciences. 2023; 13(14):8035. <https://doi.org/10.3390/app13148035>; Impact factor: 2.7 (Q2) – joint article published
2. Górski, F., Rybarczyk, D., Wichniarek, R., Wierzbicka, N., Kuczko, W., Żukowska, M., Regulski, R., Păcurar, R., Comsa, D.S., Băilă, D.I., Zelenay, M., Sanfilippo, F., Development and testing of individualized sensorized 3D printed upper limb bicycle prosthesis for adult patient Applied Sciences; August 2023, Impact factor: 2.7 (Q2) – accepted for publication
3. Górski F., Kuczko W., Rybarczyk D., Regulski R., Wichniarek R., Żukowska M., 2023, Modular upper limb prosthesis for cycling with sensors for physical activity parameters, patent application (Polish Patent Office)
4. Marciniak A., (2023), Design of mechatronic modular upper limb prosthesis, diploma thesis, Poznan University of Technology.
5. Górski F., Marciniak A., Kuczko W., Wichniarek R., Żukowska M., Rybarczyk J., 2024, Development of 3D printed low-cost individualized actuated upper limb prostheses, Proceedings of Manufacturing 2024 conference – Springer (submitted)
6. Grohs A., 2023, Use of Virtual Reality and personalized orthosis in hand therapy, diploma thesis, Poznan University of Technology.
7. Górski F., Żukowska M., Kuczko W., Wichniarek R., Siwiec S., 2023, Automated Design and 3D Printing of Therapeutic Wrist Hand Orthosis, Proceedings of HealthTech Innovation Conference, Zabrze 10-11th October 2022.
8. Górski, F., Grohs, A., Kuczko, W., Żukowska, M., Wichniarek, R., Siwiec, S., Băilă, D.I., Zelenay, M., Păcurar, R., Sanfilippo, F., Development and studies of VR-assisted hand therapy using a customized bio-mechatronic 3D printed orthosis. Electronics, September 2023; Impact factor: 2.9 (Q2) – accepted for publication
9. Górski, F., Grohs, A., Kuczko, W., Żukowska, M., Wichniarek, R., Mechatronic orthosis for upper limb used as VR game controller, 2023, patent application (Polish Patent Office)
10. Madejek J., 2023, Construction of a personalized orthosis for hand rehabilitation using the "AR" technology, diploma thesis, Poznan University of Technology.
11. Dorna P., 2023, Design of mechatronic lower limb orthoses, diploma thesis, Poznan University of Technology.
12. Dorna P., Rybarczyk J., Żukowska M., Górski F., 2023, Personalized mechatronic lower limb orthosis, 5th Conference on Biomedical Engineering, 26-27.10.2023, Poznań, Poland
13. Górski F., Dorna P., Kuczko W., Wichniarek R., Pacurar R., Sanfilippo F., Baila D., Zelenay M., 2023, Uprighting, stiffening mechatronic lower limb orthoses with a sensor system enabling gamification of rehabilitation, patent application (Polish Patent Office)
14. <https://github.com/Microttus/HapticSommerSchool/tree/main>, access: January 2023
15. Păcurar, R., Sanfilippo, F., Økter, M., Băilă, D.I., Zaharia, C., Nicoară, A.I., Radu, I.C., Tom, S., Górski, F., Kuczko, W., Wichniarek, R., Comşa, D.S., Zelenay, M., Woźniak, P., Use of high-performance polymeric materials in customized low-cost robotic grippers for biomechatronic applications: experimental and analytical research, Frontiers in Materials, September 2023; Q3 – joint article submitted / under review

Disclaimer: This result was realized with the EEA Financial Mechanism 2014-2021 financial support. Its content (text, photos, videos) does not reflect the official opinion of the Programme Operator, the National Contact Point and the Financial Mechanism Office. Responsibility for the information and views expressed therein lies entirely with the author(s).